



Repetitive Weekly REM Sleep Deprivation-Recovery Cycle Obtained from a Large U.S. Sample by Home-Based Under-Mattress Monitoring Devices

Clete Kushida^{*1}, Andrew Cotton-Clay^{*2}, Susan Baron², Laura Fava², Venkat Easwar², Arthur Kinsolving², Philippe Kahn², Jennifer Zitser¹, Anil Rama³, Feihong Ding¹
¹Division of Sleep Medicine, Stanford University, Stanford, California, USA ²Fullpower Technologies, Inc. Santa Cruz, California, USA ³The Permanente Medical Group, San Jose, California, USA
**Contributed equally to this work*

Introduction

American adults are typically sleep deprived during weekdays and attempt to recover their lost sleep on the weekends. Technological advances in home sleep monitoring have provided the opportunity to analyze sleep patterns on a scale much larger than previously imaginable. This study explores the weekly rapid-eye-movement (REM) sleep deprivation-recovery cycle in a large U.S. sample using an under-mattress monitoring device in estimating sleep continuity and architecture.

Methods

Estimated total sleep time (TST) and REM/TST (R%) were analyzed by a commercially-available home-sleep-monitoring device (Sleeptracker-AI Monitor, Fullpower Technologies, California, USA). The device passively monitors sleep using piezo-electric sensors that register the forces exerted through the mattress. The de-identified data from the devices were analyzed following review and exemption of the study (#57681) from the Stanford University IRB. Data from 07/2020-06/2021, obtained from 101,442 individuals with 14,277,964 recorded nights, were available. The analytic dataset included individuals with at least 300 nights of sleep per year and 26 of 52 nights per each day of the week (excluding nights abutting federal holidays).

Met Inclusion Criteria

21,543 Participants
11,095 Men, 51 ± 14 years
9,821 Women, 50 ± 15 years
627 Unspecified Genders

6,850,717 Recorded Nights

Device Setup

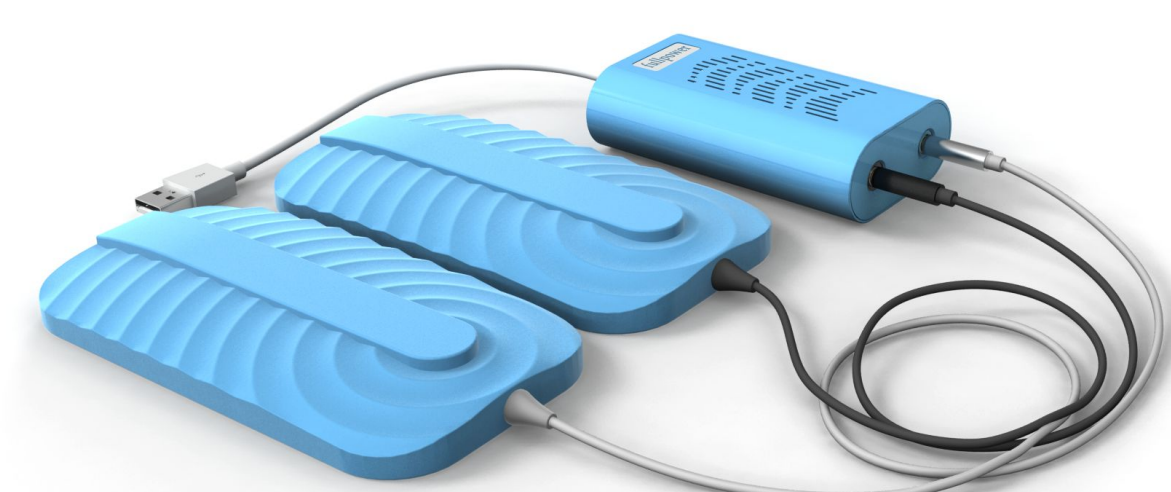
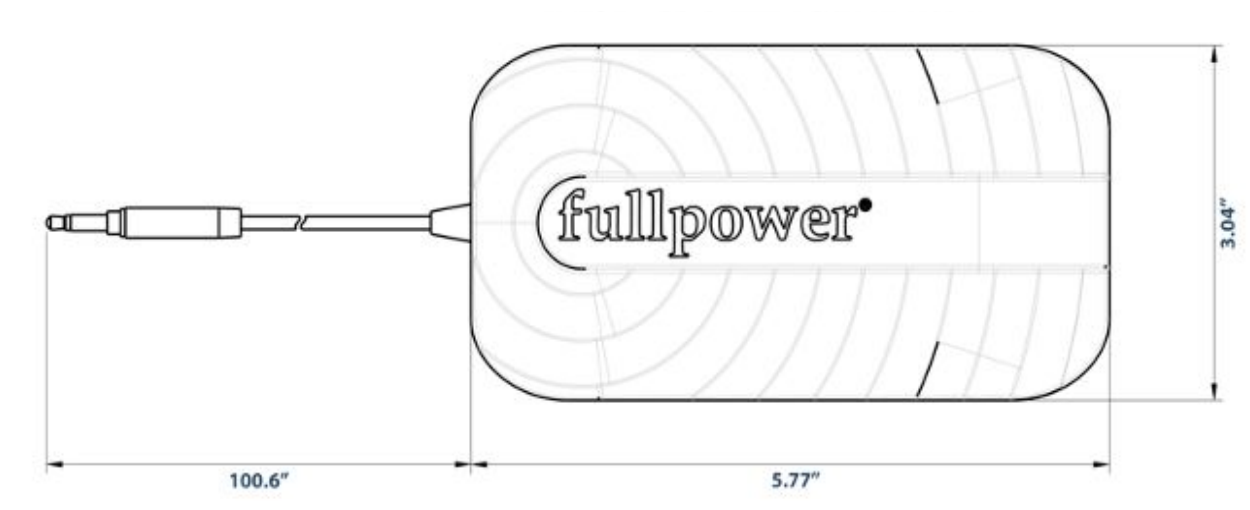
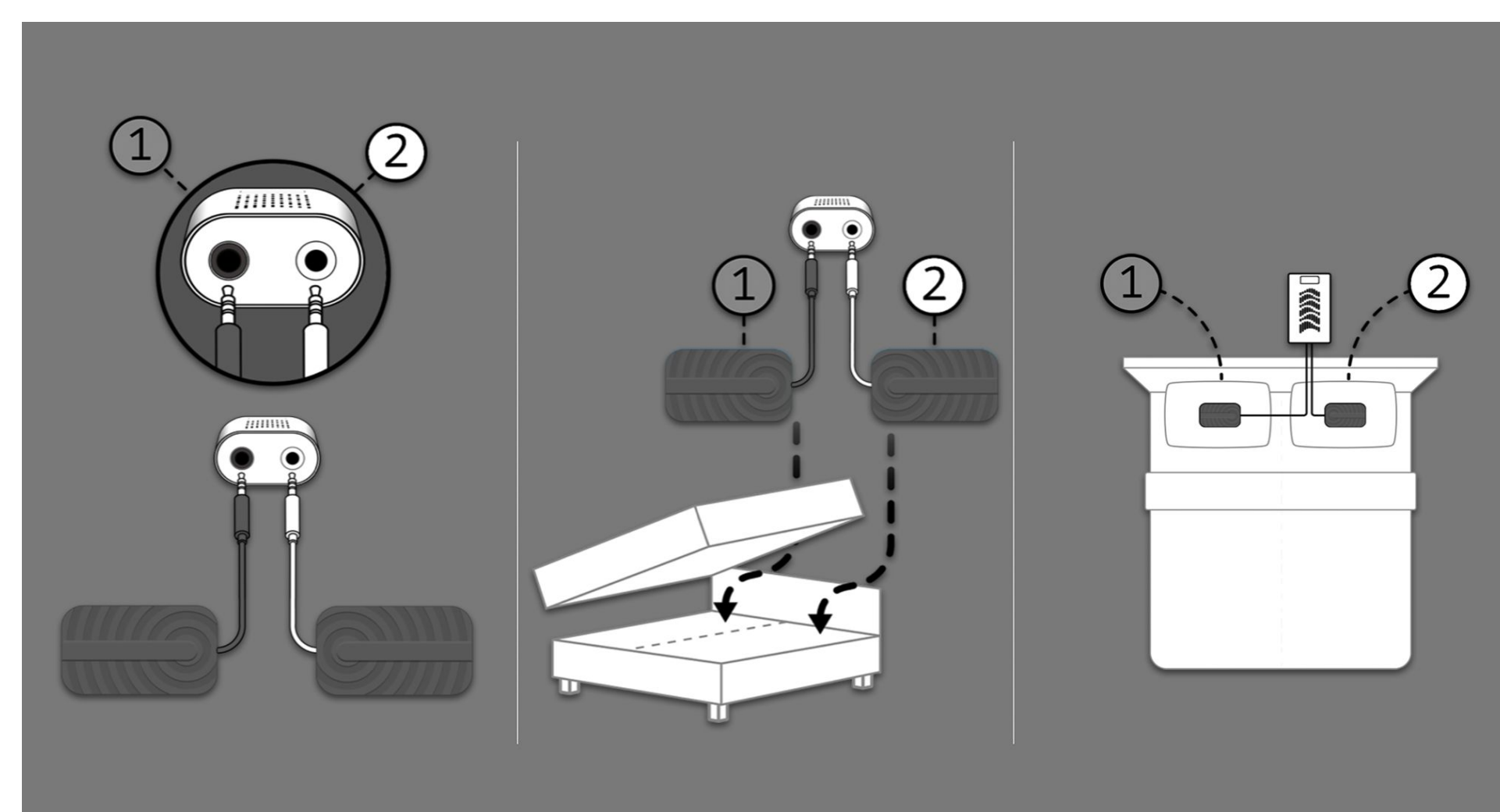

Results

There is a stepwise increase in R% from Sunday night to Friday night and a decrease back to Sunday night, following a cycle of weekday sleep deprivation and weekend recovery. The means and standard deviations (across individuals' averages) of TST in hours and R% for each night were:

Day of Week	Total Sleep Time	REM %
Sunday	7.21 ± 0.885*	24.20 ± 3.09*
Monday	7.18 ± 0.853*	24.56 ± 3.10*
Tuesday	7.16 ± 0.847*	24.67 ± 3.13*
Wednesday	7.16 ± 0.845*	24.80 ± 3.15*
Thursday	7.18 ± 0.845*	24.87 ± 3.15*
Friday	7.51 ± 0.904*	25.05 ± 3.15*
Saturday	7.59 ± 0.897*	24.83 ± 3.12*

Each statistic, when compared with the previous night of the week, was significant ($p < 0.05/7$, Bonferroni corrected) by paired t-test (denoted by an asterisk).



Conclusions

The use of advanced technology to estimate sleep-wake patterns in a large sample permits the validation of a repetitive REM sleep deprivation-recovery cycle. Individuals are, on average, partially sleep deprived starting Sunday night, which leads to a progressive REM sleep rebound that transitions into a REM recovery cycle on Friday and Saturday nights. Further work will focus on studying this cycle within different groups (e.g., age, gender), across seasons, and including other sleep parameters.

References

Ding F, Cotton-Clay A, Fava L, Easwar V, Kinsolving A, Kahn P, Rama A, Kushida C. Polysomnographic validation of an under-mattress monitoring device in estimating sleep architecture and obstructive sleep apnea in adults. *Sleep Med.* 2022 Apr 22;96:20-27. doi: 10.1016/j.sleep.2022.04.010. Epub ahead of print. PMID: 35576830.